

SPATS – an Acoustic Array at the South Pole

**S Hundertmark for the SPATS group: S Böser¹, C Bohm²,
F Descamps^{1,5}, J Fischer¹, A Hallgren³, R Heller¹, P O Hulth²,
S Hundertmark², K Krieger¹, R Nahnauer¹, M Pohl¹, B Price⁴,
K Sulanke¹ and J Vandembroucke⁴**

¹ DESY, Zeuthen, Germany

² Stockholm University, Stockholm, Sweden

³ Uppsala University, Uppsala, Sweden

⁴ University of California, Berkeley, USA

⁵ on leave of absence from Ghent University, Belgium

E-mail: Stephan.Hundertmark@physto.se

Abstract. The detection of extraterrestrial EHE neutrinos requires detection volumes at least one order of magnitude larger than currently constructed km³ optical neutrino detectors. In ice, it is anticipated that the absorption length for acoustic waves reaches up to several kilometers. This makes ice an attractive host environment for a next generation acoustic neutrino detector. To measure the acoustic properties of ice at South Pole, a test setup has been developed, ready to be deployed in the 2006/07 summer season.

Motivation

Extraterrestrial high energy neutrinos are searched for by different detectors and techniques. Currently, the most advanced are the optical Cerenkov detectors. Several projects are planned or under construction, the largest being the ICECUBE neutrino array [?]. In its final configuration it will monitor a gigaton of ice located 1.5 to 2.5km under the geographical South Pole. Several years of data have been collected, mostly by the AMANDA prototype detector. This detector is now an integral part of ICECUBE. Other neutrino telescope projects are described elsewhere [?]. Sharing some of the AMANDA holes, the RICE project is running a 20 antenna radio array and used its data to limit neutrino fluxes above 10¹⁷eV [?]. Overall much experience has been gathered for neutrino detection in ice using optical and radio techniques, but very little is known about the suitability for acoustic neutrino detection.

In [?] the absorption and scattering of acoustic waves in ice has been calculated. The main result is, that at the typical frequency of 20kHz, the scattering length is of the order of several tens of km, while the absorption length is about 8km. This has to be compared with 20m effective scattering length and 100m for absorption in the optical. Other important parameters for acoustic detection are the velocity of sound in ice and the background noise. The velocity of sound depends mainly on density and mildly on temperature. Close to the surface, the density effect dominates over the temperature effect, with the density increasing from the firn layer to the solid ice. Below this, the temperature profile of the ice induces only small variations in the speed of sound for the remaining depth of the ice. Conversely to the situation in water, noise entering the ice from the surface can not penetrate deep into the bulk, but is refracted back.

This and the fact, that ice is a dead medium, should result in an environment relatively free from background noise. If this is indeed the case, or if the movement of the ice sheet above ground, cracks in the ice or other sources of noise are present needs to be investigated.

The main goal of the SPATS array is the determination of the absorption length, the measurement of the velocity of sound as a function of depth and a long term observation of the background noise level in the ice below South Pole.

The South Pole Acoustic Test Setup

The *SPATS* detector consists of three strings, with seven acoustic stages each. Each string reaches down to 400m depth in an ICECUBE hole. Depending on hole availability during the drilling season at South Pole, it is planned to install the three strings in a triangular fashion, with leg sizes of about 100m and 400m. One string is shown in figure ???. To allow a good sampling of the upper part, where a faster change of the density of the ice is expected, the distance between the stages increases with depth. While the first two stages are spaced by 20m, this distance increases to 80m for the last two stages. The zoom-in in figure ??? shows one stage.

Such a stage consists of a transmitter module, a sensor module and two spacer balls. The spacer ball guarantee a minimal distance of the modules from the electrical cable. The modules are hollow stainless steel cylinders, with a diameter of about 12cm. The necessary electronics are located inside the housing, protected from pressure and during the refreezing process from water. The upper cylinder is the transmitter module. It basically consists of a high voltage generator and a piezo-ceramic. This ceramic extends from the bottom of the cylinder and is, after refreezing, in direct contact with the ice. High voltages pulses of approximately $10\mu\text{s}$ cause the piezo element to generate a short sound pulse, which then propagates through the ice. The pulse generation and the amplitude can be controlled remotely by software. In addition to this, temperature and pressure are measured by special sensors, as well. The sensor module is mounted below the transmitter module. Figure ??? shows a close-up of the inside. Three piezo-elements are gently pressed in a star like configuration against the wall of the steel housing. This allows for good acoustic coupling to the ice. Next to the active piezo-element, a low noise circuit amplifies the signal and sends it to the surface. This electrical signal is, depending on the position on the cable, transported over up to 400m of high grade twisted pair cable. Even so the absolute orientation of the individual sensors in azimuth is unknown, the geometrical arrangement allows for directional discrimination of the signal. For opposite sensors, and with a speed of sound of about 4km/s, the arrival time difference is of the order of tens of microseconds. At South Pole, the distances from the hole to the counting house typically are above 400m. To minimize signal distortion and reduce cable cost by such an additional cable length, the signals are digitized directly at the hole location. To this end an industrial small footprint, low power computer (String-PC) is installed, together with a DSL-modem and the necessary power supplies, in a sturdy aluminum

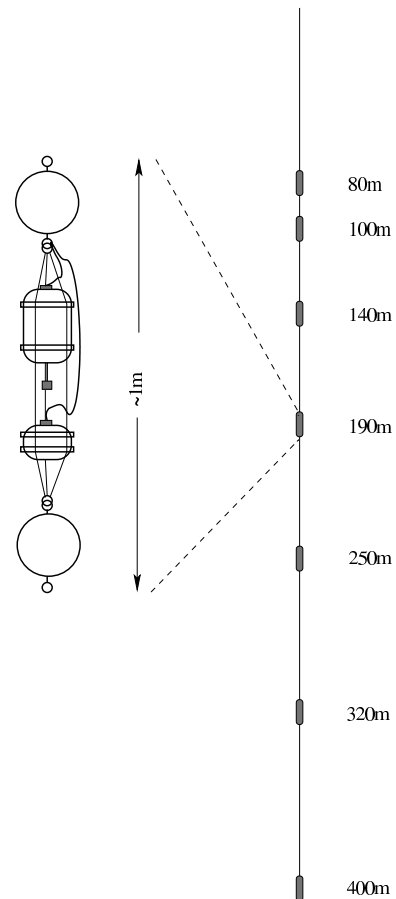

Figure 1. Schematic of one of three SPATS strings. Seven acoustic stages are arranged with increasing distances from 80m to 400m depth.

box. This box is split into two compartments, one used to connect the cables from the in-ice detector and the counting house, the other used to house the String-PC and electronics.

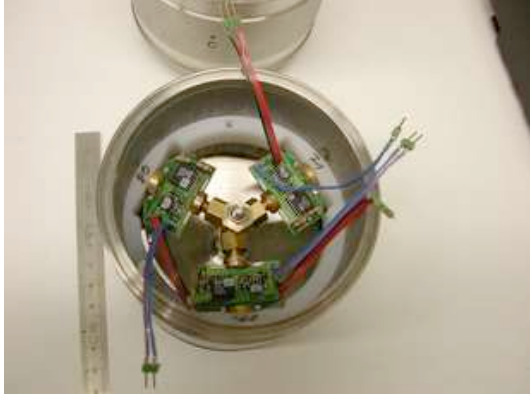

Figure 2. A closeup of the inside of an acoustic sensor module.

for Ethernet communication. DSL was chosen for this communication, as this technique allows sufficient speed over the up to 1km distance with the available cables. For time synchronization, the distributed GPS signal is decoded by the String-PCs and together with the digitized signal from the sensors reported back via the Ethernet connection. This simple synchronization scheme is allowed for due to the relaxed timing accuracy requirements (on the order of μ -seconds). More information can be found in [?].

This box is buried in the snow to protect it from the extreme temperatures during the harsh Antarctic winter. Freezer tests showed, that due to the approximately 50W power dissipated mainly by the String-PC, the inside temperature is about 20° higher than ambient temperatures.

To reduce the installation work load at South Pole no dedicated surface cables are laid to the counting house. Instead four unused pairs of the existing ICECUBE surface cable connect each of the three DAQ stations with the counting house. There, a central computer (Master-PC) is used to steer the experiment and collect the data from the String-PCs. Two of the pairs are used to supply power, one pair distributes a GPS clock signal from the Master-PC to the String-PC and the last is used

System Test in Northern Sweden



Figure 3. The test setup on Lake Torneträsk.

The detector will be constructed and operated in the harsh Antarctic environment under conditions that are not easily replicated in the laboratory. Additionally the operation of transmitter and sensors at distances of several hundred meters is impossible inside the laboratory. Therefore the functionality and robustness of the system was tested in a natural environment. To this end, part of the detector was transported to Lake Torneträsk. This lake is located in

Sweden, about 200km north of the Arctic Circle. During spring, the lake is covered by a thick ice-layer, greatly simplifying experiment setup and logistics. At the chosen location, the lake is about 50m deep, 2km wide and about 30km long. The “Abisko Scientific Research Station” from the Royal Swedish Academy of Sciences [?], located at the shore of the lake gave access to the necessary equipment and infrastructure. Figure ?? shows the setup. A temporary counting house was placed on the lake (the blue hut). In front of the hut, the aluminum box houses the cable connections and the String-PC system. Via Ethernet this box is connected to the Master-PC in the inside of the counting house. A small power generator, with backup batteries, supplied the setup with electricity.

In the forefront (middle) three acoustic stages can be seen. From the hut, two cables with one stage each connected at the end were laid out in different configurations. The stages were lowered through holes in the ice-cover into the water. Signals from the transmitter module located at one end were then received by the sensor module at the other end. With the given setup, distances of up to 800m were covered. Even under the difficult conditions on the lake, setup and operation proved to be easy and reliable. Figure ?? shows a signal that traveled 800m and was digitized by the String-PC .

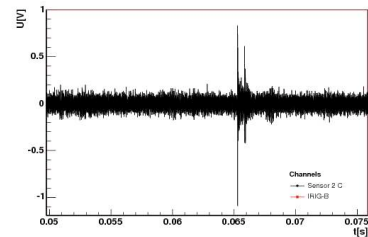

Figure 4. The acoustic pulse as seen by a sensor module, from a transmitter 800m away.

Outlook

The goal of the SPATS project is to investigate the suitability of the ice sheet under the South Pole station for acoustic neutrino detection. The setup will allow measurements of the key parameters for the propagation of acoustic waves and the background from noise. In addition, a temperature-depth profile for the depth from 80m to 400m will be measured. This information can be used, together with the acoustic measurements itself, to extract the refractive index as a function of depth. Depending on the actual absorption length in the relevant frequency range, in comparison to the size of the array, it might only be possible to give a lower limit for the absorption length. Apart from these measurements, the most critical outcome from this experiment will be the determination of the, possibly variable, noise level over a long period of time. Once the above parameters are extracted, they can be used as input to refine simulation programs. This will allow an improved investigation of the capabilities of a large acoustic array, being operated together with the existing optical ICECUBE detector and a future radio detector. Such a hybrid detector would have the unique capability to use coincident events to validate the results of the new techniques acoustic and radio.

References

- [1] The ICECUBE project web page: <http://icecube.wisc.edu>
- [2] S. Hundertmark and A. Kouchner, *Comptes Rendus Physique* **6** (2005) 789.
- [3] I. Kravchenko *et al.*, *Phys. Rev. D* **73** (2006) 082002 [arXiv:astro-ph/0601148].
- [4] P. B. Price, arXiv:astro-ph/0506648.
- [5] The Abisko Research Station, <http://www.ans.kiruna.se/ans.htm>
- [6] S. Boser, C. Bohm, S. Hundertmark, A. Hallgren, R. Nahnauer, B. Price and J. Vandenbroucke, *Int. J. Mod. Phys. A* **21S1** (2006) 221.