

# Hadron Production Measurements at CERN

**M.G.Catanesi**

Istituto Nazionale di Fisica Nucleare , Bari, Italy

**Abstract.** Hadron production measurements for neutrino experiments is a well established field at CERN since the '70s. Precise prediction of atmospheric neutrino fluxes, characterization of accelerator neutrino beams, quantification of pion production and capture for neutrino factory designs, all of these would profit from hadron production measurements. In recent years, interest in such studies was revived and new generation of low-energy (from 3 to 400 GeV) hadron production experiments were built or proposed. Such experiments all share a basic design, consisting in the presence of open-geometry spectrometers, as close as possible to full angular coverage, and aiming at full particle identification. New results are now provided by Harp in the very low energy range (3 to 15 GeV/c) and by NA49 at 158 GeV/c. In the next years NA49-future will explore the medium energy range (30 to 400 GeV/c) and at LHC energies for the first time thanks to the TOTEM experiment, it will be possible to measure with unprecedented precision the total cross section beyond 1 TeV/c.

## 1. Introduction

Hadron production data are relevant in several branches of neutrino physics.

The study of atmospheric neutrinos provides strong evidence for neutrino oscillations[1, 2]. At the same time, to quantitatively understand this phenomenon, several accelerator-based neutrino experiments are being built, and new types of neutrino beams are being designed. In either cases, detailed knowledge of the hadron cross sections at the relevant energies is now considered a must.

The design of alternative neutrino beams would profit a lot from a more detailed knowledge of the hadron production cross-sections. The optimization of the figure of merit (and the cost) of the so-called neutrino factory [3, 4] (neutrino beam produced by decays in a muon storage ring) depends on the production and collection efficiency of pions at the target station, and therefore requires a systematic study of pion production cross sections at several energies (from a few GeV to 24 GeV, depending on design choices) and with several target materials.

The calculation of atmospheric neutrino fluxes is dominated by the knowledge of the primary cosmic ray flux, of the hadron production in the interaction of the primaries with target air nuclei, and of the subsequent decay chains. Most of the uncertainty comes from the limited understanding of hadron interactions. Different Monte-Carlo simulations, depending on the model they are based on ([5, 6, 7, 8, 9] as examples), provide estimates which can differ by as much as 25% . The relevant energy range for primary particles is, in this case, from a few GeV to a few 100 GeV, while target material should be as close as possible to the constituents of the atmosphere, namely  $N_2$  and  $O_2$ .

## 2. Historical perspective

Since the 70's, in order to make a reliable prediction of the neutrino flux, the community has always been committed to measure in ancillary experiments the hadron production cross-sections, the reason being that neutrino beam composition relies on these measurements.

This first generation of hadron production experiments was mostly based on measurements of particle yield along instrumented beam lines, mainly using existing facilities. They were all single arm spectrometers with a small phase space coverage in the forward region ( $< 150$  mrad), and characterized by low statistic and/or limited number of data points.

The overall scale error, arising from the uncertainties in the spectrometer acceptances and in the absolute calibration of the primary proton beam intensity, was estimated to be 15%.

Several measurements of this kind were done at CERN. We should mention in the low energy range (around 20 GeV/c) of primary proton momentum, the experiments quoted as "Allaby" [10] and "Eichten" [11]. At higher energy we should quote the NA20 spectrometer [12], that performed a secondary particle energy scan in the range 60-300 GeV/c, and the more recent (1996) SPY experiment [13].

## 3. Present measurements: HARP

HARP at the CERN PS [14][15] was the first hadron production experiment designed on purpose, combining a large, full phase space acceptance with low systematic errors and high statistic.

These requirements come from the need of an accurate characterization of neutrino beam targets to reduce the extrapolation error to the minimum and the request of the secondary pion production cross sections informations over the full phase space (backward included) in order to optimize the design of the new neutrino beam facilities.

HARP performed extensive measurements of hadron production cross sections and secondary particle yields in the energy range 2-15 GeV over the full solid angle, using a large set of cryogenic and solid (thin and thick) targets. The experiment (see fig.1) includes a large-angle spectrometer, based on a TPC positioned in a solenoidal magnet used for tracking and  $dE/dx$  measurements and a system of RPC counters. The forward spectrometer covers polar angles up to 250 mrad. It uses a dipole magnet and large planar drift chambers for particle tracking. The particle identification is performed with a combination of time-of-flight, Cherenkov, and calorimeter informations. The larger angle region is covered by a TPC positioned in a solenoidal magnet (for tracking and  $dE/dx$  measurements) complemented by a system of RPC counters for additional particle-ID at very low momenta. In order to minimize the systematic errors, care has been taken to provide overlap regions between detectors.

By making use of a fast readout (event rate 2.5KHz), very demanding (and unprecedented at that time) for a TPC, the HARP detector was able to collect few millions of events per setting (a setting is a combination of target type and material, beam energy and polarity) insuring small statistical errors.

HARP has completed the analysis of the pion production using the K2K[16] and MiniBooNE[17] targets (proton beam of respectively 12.9 and 8.9 GeV/c). The pion yields from 3,5,8,12 GeV/c protons on Tantalum target, fitting the Neutrino Factory and protons driver conditions, is also ready. Finally, the preliminary results of pion yields from 12 GeV/c protons on Carbon target, relevant for the cosmic ray community, are now available. In the next months additional results will follow.

### 3.1. Pion production using the K2K and MiniBoone targets

The K2K experiment is most sensitive to uncertainties in the predicted neutrino spectrum in the energy range between 0.5 and 1 GeV. The distortion of the spectrum measured with the far

detector is predicted to be maximal in this range according to the neutrino oscillation parameters measured in atmospheric neutrino experiments . The transmission properties of the beam line in the K2K experiment are such that the relevant angular region for pions at production is below 250 mrad, while the relevant momentum region starts at 1 GeV/c and is essentially exhausted at 5 GeV/c, matching very well the HARP forward spectrometer acceptance. The measurement of pion production for the K2K experiment using a 5% $\lambda$  Al target and incident protons of 12.9 GeV/c momentum was recently completed [18] .

After applying all corrections, the data were fitted with a Sanford-Wang empirical parametrization. This reason of this choice is to make comparison easier with similar measurements and to use HARP data in the K2K beam montecarlo, allowing a direct translation of the pion production uncertainties into flux uncertainties. In fig.2 a ratio is shown between the neutrino flux measured at the near and at the far detector as a function of the neutrino energy. The boxes indicated the uncertainties obtained using the K2K Montecarlo and the errored points are obtained using the HARP data.

A comparison of the errors on the near/far ratio before and after the inclusion of the HARP results show a reduction by a factor of two.

The case for the MiniBooNE measurement is equally compelling. Here too the neutrino flux comes predominantly from the  $\pi$  decay into  $\mu + \nu$ . Again in this case the HARP experiment covers the relevant range, in energy from 0.75-6.5 GeV/c and in angle from 30-210 mrad (more than 80% of the phase space).

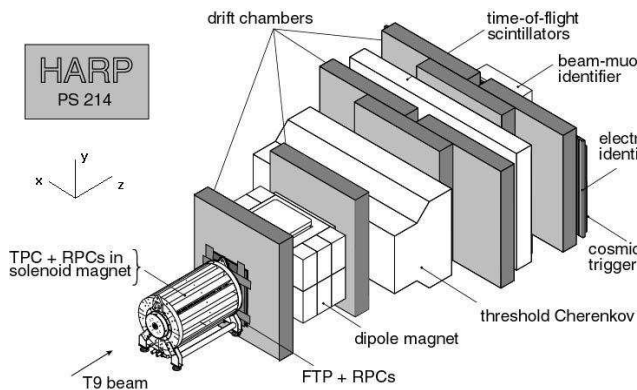

**Figure 1.** The HARP Detector at the CERN PS.

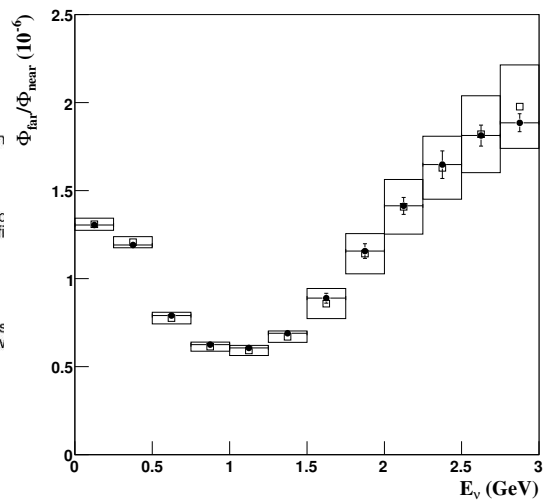

**Figure 2.** Plot showing the near to far ratio in the K2K experiments measured by the K2K MonteCarlo (boxes) and results from the Harp experiment (errored points).

### 3.2. Pion production from 3,5,8,12 GeV/c protons on Tantalum target

One of the main motivations of the HARP experiment is the measurement of the yields of positive and negative pions for a quantitative design of a proton driver and a target station of a future neutrino factory. The variables affecting the pion production are incident proton beam energy, target material and target geometry (diameter and length). The total proton-beam power is only a scaling parameter. In order to achieve the highest number of potentially

collected pions of both charge signs per unit of energy a pion production measurement should give the information necessary to optimize both proton beam energy and target material.

At the moment, a CERN scenario for a Neutrino Factory foresees a 3 GeV/c or 5 GeV/c proton linac with a high- $Z$  target material [19]. Even if this is not the only one studied scenario, in most of the cases high- $Z$  materials are proposed as targets. For this reason it was decided to first analyze a series of settings taken with a range of different beam momenta incident on a Tantalum (Ta) target.

For this purpose, pions produced by proton beams (with momentum from 3 to 12 GeV/c) hitting a Ta thin (5%  $\lambda_{int}$ ) target are best measured in the large-angle spectrometer.

In Fig. 3 the yields for positive and negative pions within the acceptance of typical neutrino factory designs are shown as a function of beam momentum.

Similar data-sets on lead, tin, copper, aluminium, carbon and beryllium have been collected. These are currently being analysed and will be presented in the future.

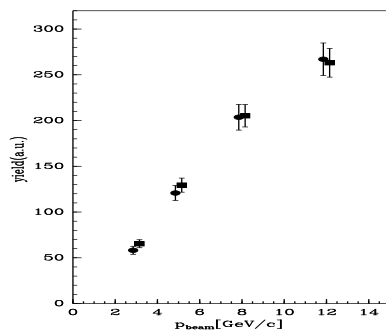

**Figure 3.** Yields for positive (circle) and negative (boxes) pions within the acceptance of typical neutrino factory designs as a function of beam momentum.

### 3.3. Pion production from 12 GeV/c protons on Carbon target

Preliminary results on pion production by 12 GeV/c protons impinging on a Carbon target have been recently presented by the HARP collaboration. These measurements (the first at low energy) are interesting for the cosmic ray physics community.

In Fig. 4 pion yields are shown in the angular range between 30 to 210 mrad for 9 different momentum bins ranging from 0.75 to 8 GeV/c.

## 4. Future measurements: NA49 and TOTEM

### 4.1. NA49-future

The NA49 experiment is a large acceptance hadron spectrometer at the CERN-SPS for the study of the hadronic final states produced by collisions of various beam particles (including nuclei) of different energies on a variety of fixed targets.

The main tracking devices are four large volume Time Projection Chamber (TPCs). The NA49 TPCs allow precise measurements of particle momenta and type, and are supplemented by two time of flight (TOFs) detector arrays and a set of calorimeters for additional particle-ID.

An upgrade of the NA49 detector was recently proposed at CERN [20]. It mainly consists in the replacement of the old TPC read-out electronic in order to speed-up the data acquisition rate of a factor 10, in order to match the demand for high-precision measurements. The proposed physics program includes measurements of hadron production in hadron-nucleus interaction needed for neutrino (T2K[21]) and cosmic-ray experiments (Auger[22], KASCADE [23])

The T2K experiment will study oscillation of an off axis neutrino beam between the J-Parc accelerator and the Super-Kamiokande detector. Its neutrino beam is produced from a primary

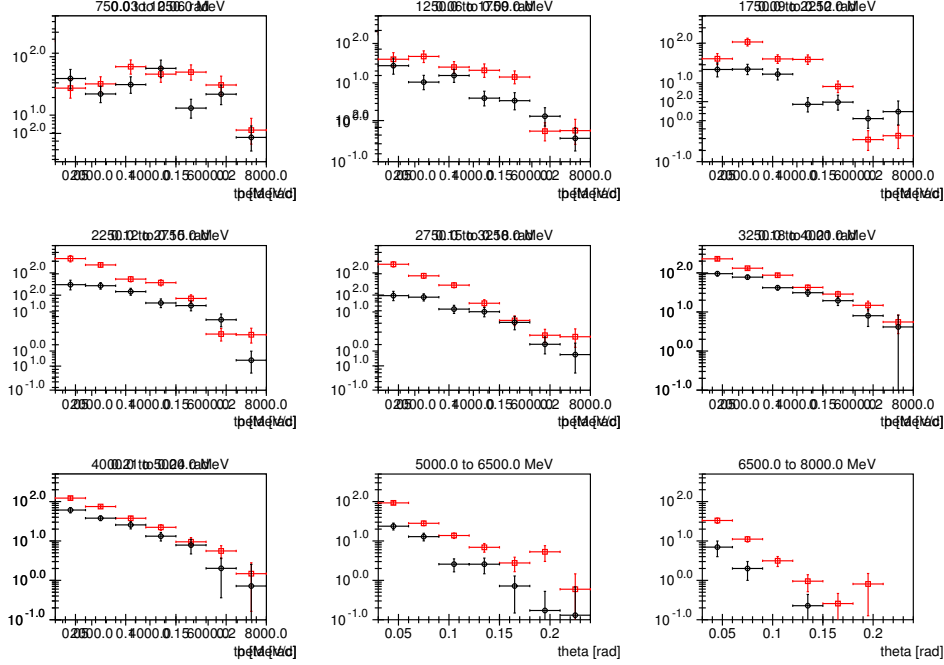

**Figure 4.** Pion yields for positive (red) and negative (black) particles in the angular range between 30 to 210 mrad for 9 different momentum bins ranging from 0.75 to 8 GeV/c.

50 GeV/c proton beam (30 GeV/c in a first phase) hitting a Carbon target.

The T2K results will not be statistics limited, so in order to achieve the required precision the control of the systematics will be a must. The HARP measurements, performed for the K2K beam, demonstrated that the larger source of systematic error (the near to far flux ratio) can be reduced by a factor two by the appropriate knowledge of the hadron production [24]. Following this example, NA49-future plans to measure the primary proton-Carbon cross section at 50 GeV/c (30 GeV/c) using a replica of the T2K target and several Carbon targets of various thickness.

It is well known in cosmic ray physics that at high energy the measurements are based on the analysis of secondary particle showers produced in the atmosphere. The interpretation in terms of primary particle type and energy relies strongly on hadron production models.

Only recently it has been realized that interactions in the energy range up to few hundred GeV give rise to large uncertainties. To cover the lack of measurements in this energy range NA49-future plans to collect the following sample of data:

- $p - C$  30, 100, 250, 400 GeV
- $\pi_+ - C$  30, 100, 250 GeV
- $\pi_- - C$  30, 100, 250 GeV

The Carbon target was chosen due to the similarities of the secondary particle distributions in p-C and p-Air interactions.

## 4.2. TOTEM

Totem is the only LHC experiment that will explore the forward region at pseudorapidity larger than 3.1 The main goal is the measurement of the total and elastic cross-section at 14 TeV and the study of diffractive physics in the forward region. The experiment is approved and funded and will start the data taking end 2007.

The total cross section beyond 1 TeV/c will be measured with the unprecedented precision of 1 % using the luminosity independent method based on the simultaneous detection of elastic scattering at low momentum transfer and of the inelastic interactions. Protons scattered at very small angles in elastic or quasi-elastic reactions will be measured in telescopes of silicon detectors enclosed in *Roman Pots*, placed on both sides of the intersection regions. Inelastically produced secondaries will be measured by a forward inelastic detector covering the region  $3 < \eta < 7$  with full azimuthal acceptance. This last detector will measure the overall rate of inelastic reactions. Totem shares the interaction point with the CMS experiment, and a common Physics TDR by the two collaborations is in preparation, showing an extensive common physics program.

This program will include for the first time the measurement of the very forward energy flux essential for a better understanding of the cosmic ray events.

## References

- [1] Y. Fukuda (SuperKamiokande Collaboration), **B433** (1998) 9; **81** (1998) 1562.
- [2] T. Kajita, **B77** (1999) 123.
- [3] B. Autin ,Prospective study of muon storage rings at CERN, CERN 99-02 (1999).
- [4] A.Blondel et al. ECFA/CERN Studies of a European Neutrino Factory Complex CERN-2004-002 - ECFA-04-230.
- [5] T.K.Gaisser et al.,Phys.Rev.D54 (1996)5578.
- [6] M.Honda,Nucl.Phys.B77 (1999)140.
- [7] G.Battistoni et al., ph/907408 (1999).
- [8] V. Agrawal (Bartol group), **D53** (1996) 1314.
- [9] R. Engel Nucl.Phys.B (Proc.Suppl.) **122**, 40 (2003)
- [10] J.V.Allaby et al.,CERN report 70-12 (1970).
- [11] T.Eichten et al.,Nucl.Phys.B44 ,(1972)333.
- [12] H.W. Atherton et al.,CERN report 80-07 (1980).
- [13] G. Ambrosini et al.,Eur. Phys. J. C10 (1999) 605-627.
- [14] M.G.Catanesi et al., CERN-SPSC-99-35 (1999).
- [15] M.G.Catanesi et al.NIM A .in print pp 1-35(2006).
- [16] Y. Oyama ,“K2K (KEK to Kamioka) neutrino oscillation experiment at KEK-PS ”,hep-ex/9803014.
- [17] E. Church *et al.*,“A proposal for an experiment to measure muon-neutrino  $\rightarrow$  electron-neutrino oscillations and muon-neutrino disappearance at the Fermilab Booster: BooNE ”, FERMILAB-P-0898.
- [18] M.G.Catanesi et al Nucl.Phys.B732:1-45,2006.
- [19] M. Apollonio et al., Oscillation Physics with a Neutrino Factory *CERN TH2002-208*.
- [20] N. Antoniou et al..CERN-SPSC-P-330, Nov 2006. 90pp.
- [21] Y. Itow *et al.*, “The JHF-Kamioka neutrino project ” hep-ex/0106019.
- [22] T. Antoni et al. NIM A 513, 490 (2003).
- [23] J. Abraham et al. NIM A 523, 50 (2004).
- [24] M.H. Ahn et al. Phys.Rev.D74:072003,2006.